

FTK600E

Light weight, easy to fit

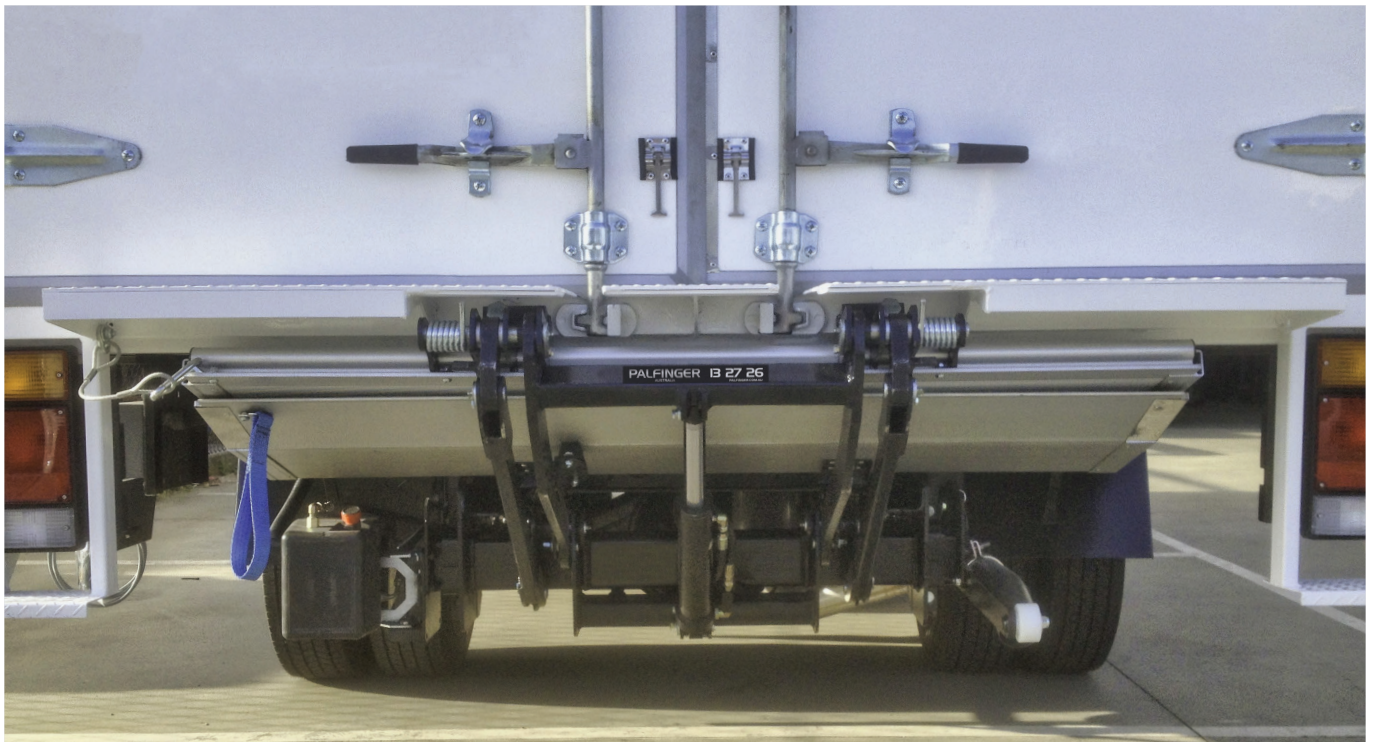

The FTK600E is a compact tail lift with a foldable platform and a loading capacity of up to 600kg. This results in an optimal weight-to-capacity ratio. The low weight is achieved with an aluminium platform and innovative design. The folding platform stows under the vehicle chassis and is simple to operate and quick to install. Comes standard with mechanical auto-levelling for increased stability when lifting larger loads.

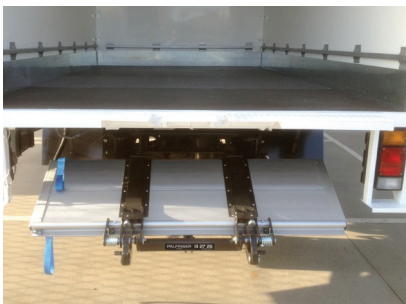

Designed and manufactured for Australian conditions.

FEATURES: Fixed control, pendant control, platform auto levelling

PALFINGER AUSTRALIA

PHONE: 13 27 26

palfinger.com.au

info@palfinger.com.au

A  Motors Company

MELBOURNE • SYDNEY • NEWCASTLE • BRISBANE • PERTH

FTK600E

Specification	FTK600E
Lift Capacity	600kg
Nominal Platform Size	1530mm W x 950mm L
Platform Finish & Construction	Anodised 2 piece single fold extruded aluminum alloy
Load Centre	500mm
Nominal Unit Weight Installed	150kg (Extension plate built into truck floor). 180kg (Extension plate added to vehicle)
Nominal Centre Of Gravity Of Unit When Stowed	340mm
Nominal Fitting Requirements	1100mm maximum floor height unloaded 800mm minimum floor height loaded *800mm min. underbody clearance for 800mm floor height *720mm min. underbody clearance for 1100mm floor height
*Subject To Vehicle Type & Floor Height	
Adds To Vehicle Length	N/A (0mm) for extension plate built in as part of body length 205mm for extension plate added to body length
Battery Isolation Switch	Yes
Controls	Removable IP65 rated two (2) button hand control c/w 2.75m lead plus fixed controls in lockable weather-proof metal box
Lifting Operation	Power up / gravity down – automatic levelling at ground
Speed Down	Adjustable flow control factory pre-set to maximum 100mm/sec complete with velocity fuse
Closing / Opening Operation	Manual (torsion spring assisted opening and closing)
Platform Stowed Lock	Manual cable & hasp
Low Maintenance Bushes	Yes
Pins	Zinc plated Ø25 mm dia. high grade bar
Hydraulic Power Pack	Heavy duty 0.8kw in weather-proof noise dampening enclosure

Diagram

a (mm)	Q (kg)
500	600

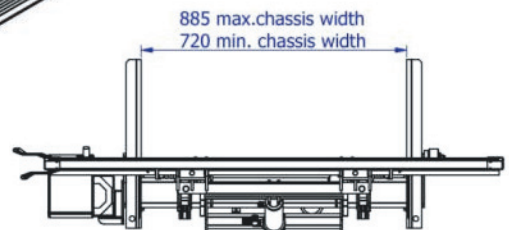
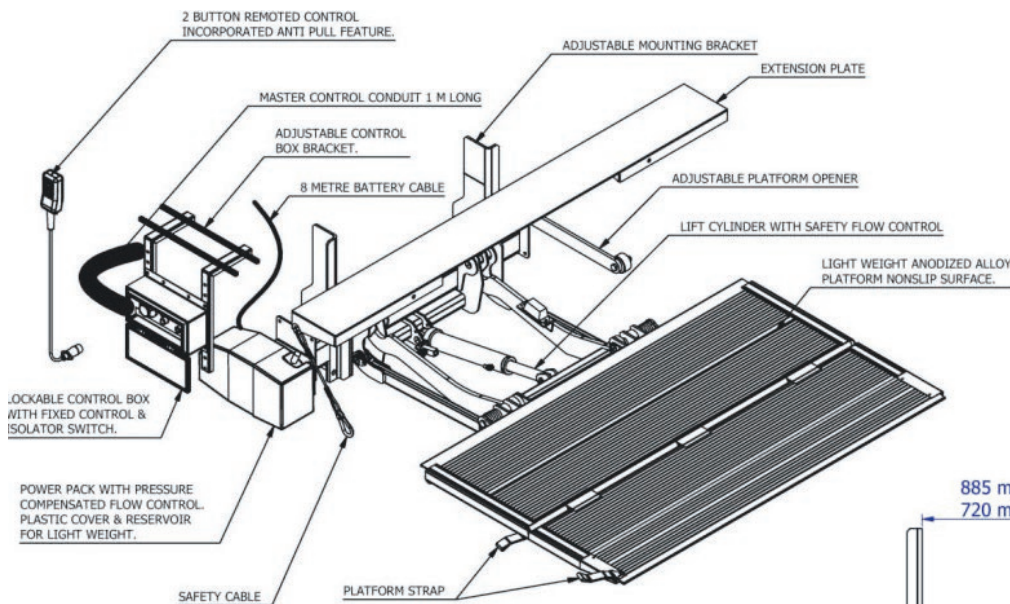
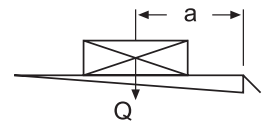

Disclaimer: The specified weights refer to the lightest platforms of the corresponding height. Dimensions may vary. Specifications subject to change without notice.

PALFINGER AUSTRALIA

PHONE: 13 27 26

palfinger.com.au info@palfinger.com.au



MELBOURNE • SYDNEY • NEWCASTLE • BRISBANE • PERTH