



PALFINGER



TAIL LIFTS

The partnership between Palfinger Australia and prestige brand PALFINGER offers a comprehensive range of high-performance tail lifts to the Australian market. PALFINGER delivers a product that is synonymous with the outstanding quality of the PALFINGER name along with decades of experience in tail lift development and market leadership.



German designed
German manufactured
Quality guaranteed



MBB F 1000 L 6-7

MBB F 1500 L 8-9

MBB C 750 S 10-11

MBB C 1500 L / C 2000 L 12-13

MBB C 1000 S / C 1500 S 14-15

MBB C 2000 S 16-17

MBB C 3000 S 18-19

MBB R 2000 S 20-21

FTK600E 22-23

BROADER APPLICATIONS 24

SERVICE & SUPPORT 25

Manufactured in-house

The hydraulic cylinder is one of the most important parts of a tail lift. That's why PALFINGER only trusts one supplier - *itself!* PALFINGER manufactures around 65,000 cylinders per annum to meet global demand.



Powerful, reliable ...

Power opening and power closure using dual-acting hydraulic cylinders. Therefore not relying on spring force or gravity alone – so the platform opens and shuts easily even on the steepest of inclines.



... and safe!

Every cylinder is fitted with flow control valves which safely control the descent of a fully loaded platform, even in the event of a burst hose in the hydraulic circuit.

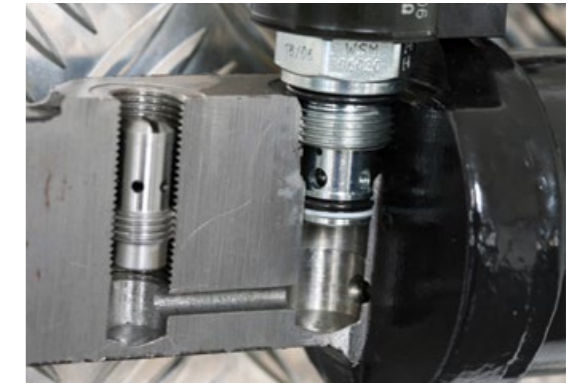

Easy to maintain

The powerpack is housed in the main beam, out of harms way, and is easily pulled out for inspection and maintenance. In addition, noise from the hydraulic pump is greatly reduced when the lift is being used in residential areas or at night



FEATURES & BENEFITS



A good greasing ...

PALFINGER'S stainless steel pivot pins are solid and not weakened by lubrication holes. 12 grease nipples for the bearings are located on the exterior of the cylinder ends to ensure direct delivery of grease to the bearings.



... for smooth operation!

A series of evenly-distributed lubrication holes guarantee an even application of grease.



Controls for all applications



PALFINGER offers a range of tail lift controls to suit individual requirements, including two-handed external controls, internally mounted controls, pendant controls, platform-mounted foot controls and wireless remote controls. External controls, pendant controls and platform-mounted foot controls (except for MBB F 600 L and steel mesh platforms) are standard inclusions with all lifts.

24-hour operation

The ergonomic control box has translucent instructions lit by an interior light making it possible to operate the lift safely 24/7 – even in the dark!



For your safety: LED warning lights

Using the latest LED technology (EN 1756-1) PALFINGER'S platform-mounted flashing warning lights operate whenever the lift is being used, ensuring the lift is fully visible at all times from the rear and from the side, providing additional safety.

FEATURES & BENEFITS



Keeping your load safe

Platform roll stops are simple to operate, robust and reliable, protecting your load whilst travelling on the platform.



MBB Control: Speedy diagnostic fault finding

Fully electronic with sensor control and electronic memory functions. In the event of lift or component failure, the diagnostic software enables the service engineer to rapidly identify the problem reducing lift downtime and repair costs.



'Intelligent' foot controls

'Intelligent' foot controls are able to distinguish between contact with the operator's foot and the load! Should goods be resting on the foot controls the lift remains static.

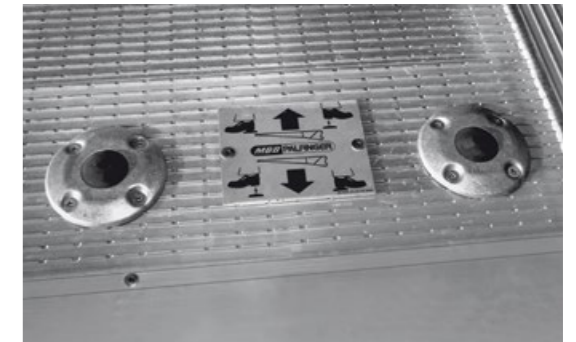

Robust, KTL protected steel mechanisms & platforms

PALFINGER'S steel mechanisms and platforms are coated with KTL protection as standard. The protective layer minimises the consequences of stone-chip damage and prevents rust spreading. This KTL coating has been subjected to a salt-spray test:

1000 hours in compliance with EN ISO 12 944-2 C5M

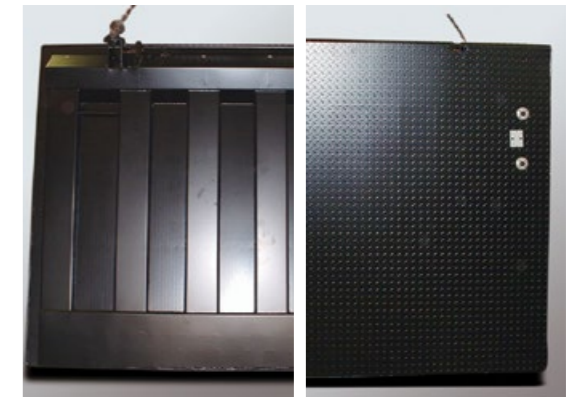

PALFINGER AUSTRALIA

PHONE: 13 27 26

palfinger.com.au info@palfinger.com.au



PALFINGER AUSTRALIA

PHONE: 13 27 26

palfinger.com.au info@palfinger.com.au



MELBOURNE • SYDNEY • NEWCASTLE • BRISBANE • PERTH

MELBOURNE • SYDNEY • NEWCASTLE • BRISBANE • PERTH

MBB F 1000 L



Short overhang,
easy to assemble

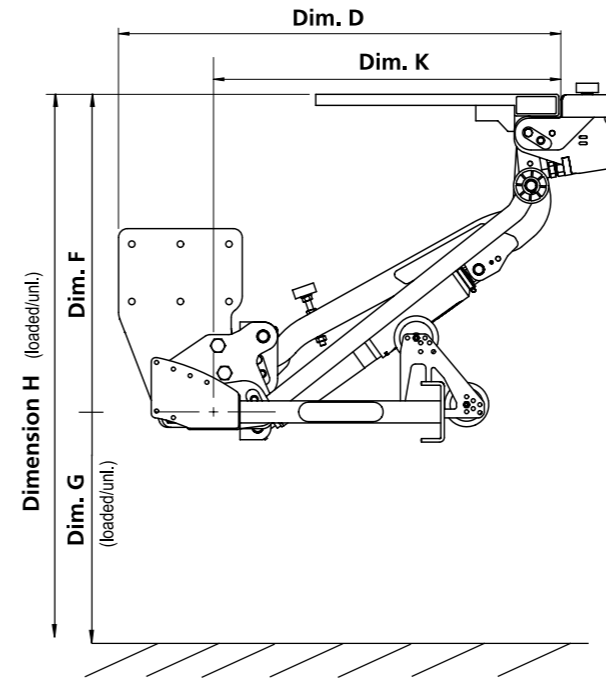

The double-folded MBB F 1000 L is a light, foldable two-cylinder tail lift which is mounted underneath the rear of the vehicle. Its 1000 kg lifting capacity ensures secure handling of pallets and trolleys alike. The MBB F 1000 L offers stability due to two lift cylinders and two parallel arms. Ground tilting of the aluminium platform is mechanical.

FEATURES: Fixed control • pendant control • platform auto levelling
• roll stops • flashing lights • foot controls

Dimensions

		F 1000 L
Lift arms (in mm)		800
H (max.)	Loading height unloaded	1175
H (min.)	Loading height loaded	970
F (min.)		640
F (max.)	Middle of the main beam to the upper edge of the loading floor	715
G (max.)	Unloaded (middle main beam till ground)	460
G (min.)	Loaded	330
E (max.)	Outer frame width (max.)	864
E (min.)	Outer frame width (min.)	850
D (min.)	Installation space	K+340
K (max.)	At dimension F (min.)	844
K (min.)	At dimension F (max.)	787

		F 1000 L
Weights		
Platform type aluminium		
Platform width (mm)		2030
height (mm)		1200
weight (kg)		299

		F 1000 L
Technical Data		
Lifting capacity		1000 kg
Main beam		180 x 180 mm
Lifting gear hydraulics		2 lifting cylinders
Lift arm pitch		750 mm
Load centre - lengthwise		600 mm
Load centre - across centre		centred, 50 % of the full load on one side
inclination angle of the platform		+8° to -8°

Diagram

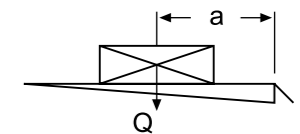

F 1000 L	
a (mm)	Q (kg)
600	1000
750	800
950	600

Disclaimer: The specified weights refer to the lightest platforms of the corresponding height. Dimensions may vary. Specifications subject to change without notice.

PALFINGER AUSTRALIA

PHONE: 13 27 26

palfinger.com.au info@palfinger.com.au



PALFINGER AUSTRALIA

PHONE: 13 27 26

palfinger.com.au info@palfinger.com.au



MELBOURNE • SYDNEY • NEWCASTLE • BRISBANE • PERTH

MELBOURNE • SYDNEY • NEWCASTLE • BRISBANE • PERTH

MBB F 1500 L



Robust, and ideal for refrigerated vehicles

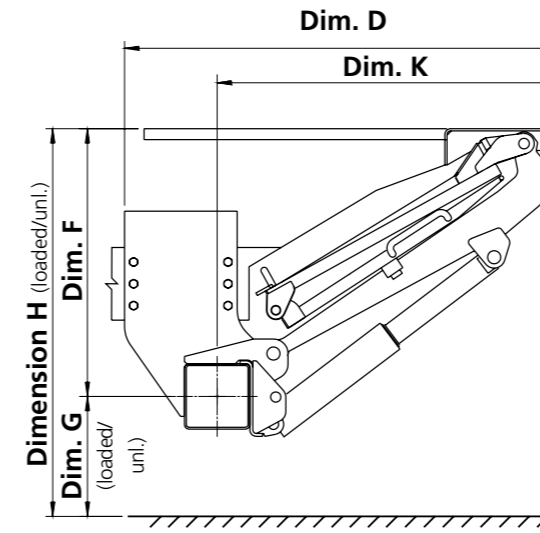

The MBB F 1500 L is a lightweight, 2-cylinder tuckunder tail lift, with an aluminium platform capable of lifting 1500 kg at a 600mm load centre. Its folding platform stows under the vehicle chassis, providing clear access to the rear of the vehicle when required.

It comes with a large, 1415mm deep platform, designed for dry freight applications, making it ideal for lifting pallets and trolleys alike. With two lift-cylinders and parallel support arms, stable operation is ensured at all times.

Added safety is achieved with Palfinger's proven mechanical auto levelling system.

The powerpack is mounted in the main beam for low noise and protection against the elements.

- FEATURES:** Fixed control • pendant control • platform auto levelling
• roll stops • flashing lights • foot controls

Dimensions

		F 1500 L
Lift arms (in mm)		900
H (max.)	Loading height unloaded	1455
H (min.)	Loading height loaded	1085
F (max.)	Middle of main beam to upper edge of loading floor	815
K (min.)	At dimension F (max.)	841
D (min.)	Installation space (min.)	1181
F (min.)		685
K (max.)	At dimension F (min.)	958
D (max.)	Installation space (max.)	1291
G (max.)	Unloaded (middle of main beam to ground)	640
G (min.)	Loaded	400
E (max.)	Vehicle frame width (max.)	980
E (min.)	Vehicle frame width (min.)	650

Technical data

		F 1500 L
Lifting capacity		1500 kg
Main beam		180 x 180 mm
Lifting gear hydraulics		2 lifting cylinders
Lift arm pitch		1310 mm
Load centre - lengthwise		600 mm
Load centre - across centre		50 % of the full load on one side
Inclination angle of the platform		+8° to -8°

Weights

		F 1500 L
Platform type		Alum.
width (mm)		2070
height (mm)		1415
weight (kg)		335

Diagram

F 1500 L

a (mm)	Q (kg)
600	1500
720	1250
900	1000
1200	750

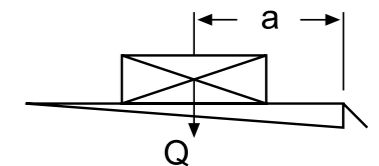

Disclaimer: The specified weights refer to the lightest platforms of the corresponding height. Dimensions may vary. Specifications subject to change without notice.

PALFINGER AUSTRALIA

PHONE: 13 27 26

palfinger.com.au info@palfinger.com.au



PALFINGER AUSTRALIA

PHONE: 13 27 26

palfinger.com.au info@palfinger.com.au



MELBOURNE • SYDNEY • NEWCASTLE • BRISBANE • PERTH

MELBOURNE • SYDNEY • NEWCASTLE • BRISBANE • PERTH

MBB C 750 S

PALFINGER

Lightweight four cylinder cantilever

PALFINGER



The MBB C 750 S tail lift is specially designed for small vehicles up to 7.5 tonne gvm. The lift features a strong, lightweight aluminium or steel mesh platforms and a robust four-cylinder lift mechanism with an overall lift weight of only 224 - 230kg (dependant on platform) A three-piece screwable, under-run bumper is standard. Universal mounting brackets enable quick installation to virtually all types of chassis.

FEATURES: Fixed control • pendant control • platform auto levelling
(Aluminum platform only: roll stops • flashing lights • foot controls)

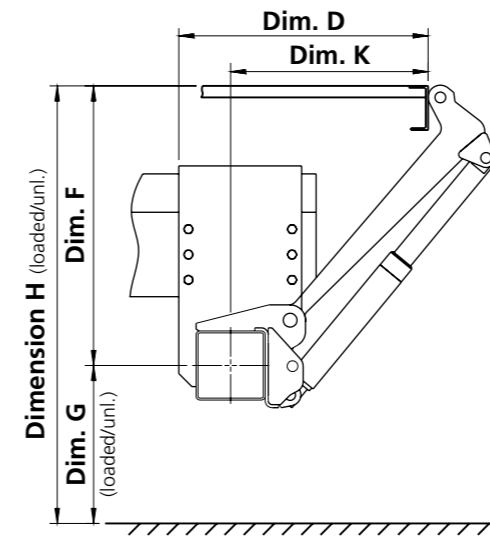

Weights

C 750 S	
Platform type	Alum.
Platform width (mm)	2100
Platform height (mm)	1550
Adds to vehicle (mm)	185*

C 750 SM	
Platform type	Steel Mesh
Platform width (mm)	1900
Platform height (mm)	1300
Adds to vehicle (mm)	185*

* Does not include seal kit or pressing

Dimensions

C 750 S / C 750 SM		
Lift arms (in mm)		680
H (max.)	Loading height unloaded	1190
H (min.)	Loading height loaded	880
F (max.)	Middle of main beam to upper edge of loading floor	640
K (min.)	At dimension F (max.)	503
D (min.)	Installation space (min.)	601
F (min.)		490
K (max.)	At dimension F (min.)	624
D (max.)	Installation space (max.)	722
G (max.)	Unloaded (middle of main beam to ground)	550
G (min.)	Loaded	390

Technical data

C 750 S / C 750 SM	
Lifting capacity	750 kg
Main beam	120 x 80 x 5 mm
Lifting gear hydraulics	2 x lift cylinder / 2 x tilt cylinder
Platform overlap with floor	- 44 mm
Lift arm pitch	1240 mm
Load centre - lengthwise	600 mm
Load centre - across centre	50 % of the full load on one side
Inclination angle of the platform	+90° to -10°

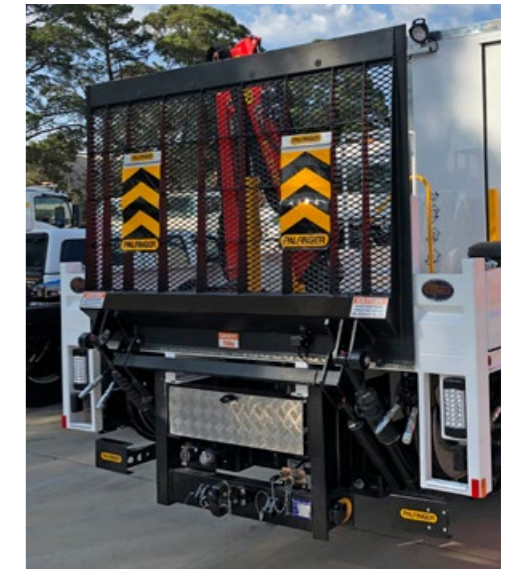

The MBB C 750 SM tail lifts platform is specially designed for Australia and is suitable for small vehicles up to 7.5 tonne gvm. The lift features robust four-cylinder lift mechanism with an overall lift weight of only 230 kg. Available platform sizes 1300 mm height with 1900 and 2200mm width options. A three-piece screwable, under-run bumper is standard. Boltable mounting brackets enable quick installation to virtually all types of chassis.

Diagram

C 750 S / C 750 SM

a (mm)	Q (kg)
600	750
700	650
820	550
1120	400

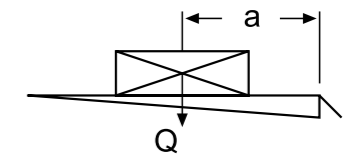

Disclaimer: The specified weights refer to the lightest platforms of the corresponding height. Dimensions may vary. Specifications subject to change without notice.

PALFINGER AUSTRALIA

PHONE: 13 27 26

palfinger.com.au info@palfinger.com.au



PALFINGER AUSTRALIA

PHONE: 13 27 26

palfinger.com.au info@palfinger.com.au



MELBOURNE • SYDNEY • NEWCASTLE • BRISBANE • PERTH

MELBOURNE • SYDNEY • NEWCASTLE • BRISBANE • PERTH

MBB C 1500 L



The efficient and functional tail lift

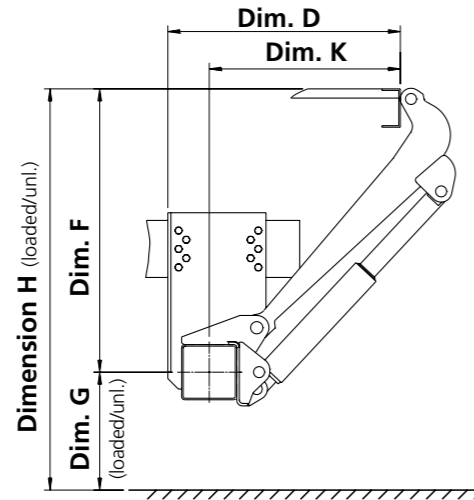

Weights

C 1500 L	
Platf. type	Alum.
Platform width (mm)	2450
Platform height (mm)	2200
Adds to vehicle (mm)	203

Dimensions

C 1500 L		
Lift arms (in mm)		
H (max.)	Loading height unloaded	1256
H (min.)	Loading height loaded	906
F (max.)	Middle of main beam to upper edge of loading floor	728
K (min.)	At dimension F (max.)	515
D (min.)	Installation dimension (min.)	665
F (min.)		529
K (max.)	At dimension F (min.)	710
D (max.)	Installation dimension (max.)	860

Technical data

C 1500 L		
Lifting capacity		1500 kg
Main beam		180x180 mm
Lifting gear hydraulics		2 x lift cylinder 2 x tilting cylinders
Lift arm pitch		1310 mm
Load centre - lengthwise		600 mm
Load centre - across centre		50 % of the full load on one side
Inclination angle of the platform		+90° to -10°
Platform overlap with floor		-57mm

Diagram C 1500 L

a (mm)	Q (kg)
600	1500
720	1250
900	1000
1200	750

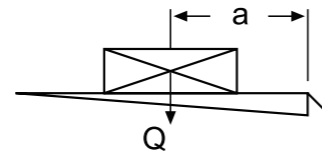

Disclaimer: The specified weights refer to the lightest platforms of the corresponding height. Dimensions may vary. Specifications subject to change without notice.

FEATURES: Fixed control • pendant control • platform auto levelling • roll stops • flashing lights • foot controls

MBB C 2000 L



Greater transport capacity, fewer costs

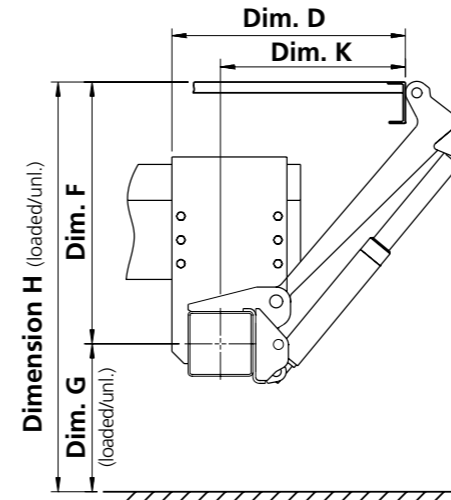

Weights

C 2000 L	
Platf. type	Alum.
Platform width (mm)	2450
Platform height (mm)	2200
	548 kg
	565 kg
	575 kg
Adds to vehicle (mm)	235

Dimensions

C 2000 L		
Lift arms (in mm)		
H (max.)	Loading height unloaded	1428
H (min.)	Loading height loaded	916
F (max.)	Middle of main beam to upper edge of loading floor	817
K (min.)	At dimension F (max.)	601
D (min.)	Installation dimension (min.)	751
F (min.)		566
K (max.)	At dimension F (min.)	820
D (max.)	Installation dimension (max.)	970

Technical data

C 2000 L		
Lifting capacity		2000 kg
Main beam		180x180 mm
Lifting gear hydraulics		2 x lift cylinder 2 x tilting cylinders
Lift arm pitch		1300 mm
Load centre - lengthwise		750 mm
Load centre - across centre		Central, 50 % of the full load on one side
Inclination angle of the platform		+90° to -10°
Platform overlap with floor		-63mm

Diagram C 2000 L

a (mm)	Q (kg)
750	2000
900	1650
1100	1300
1600	950
2400	600

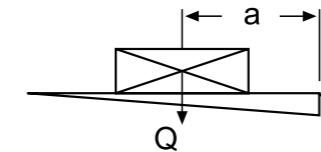

Lifting a full 2000kg at 750mm load centre, the MBB C 2000 L is designed for general freight applications. Its reliable and heavy duty four-cylinder lift mechanism with power opening and power closing dualacting cylinders is available with aluminium platforms, up to a maximum height of 2600mm. Standard features apply as does the power pack housed in the main beam, stainless steel pivot pins, diagnostics software, sensor control and electronic memory functions.

Disclaimer: The specified weights refer to the lightest platforms of the corresponding height. Dimensions may vary. Specifications subject to change without notice.

FEATURES: Fixed control • pendant control • platform auto levelling • roll stops • flashing lights • foot controls

MBB C 1000 S

PALFINGER

Robust, dependable and efficient

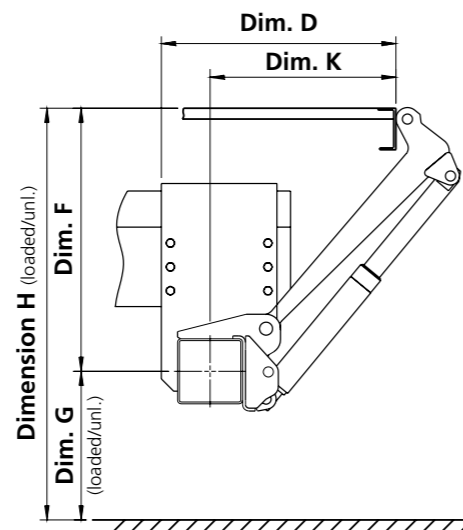

Weights

C 1000 S	
Platform type	Alum.
Platform width (mm)	2450
Platform height (mm)	2050
Unit weight (kg)	401
Adds to vehicle (mm)	203*

* Does not include seal kit or pressing

Dimensions

C 1000 S	
Lift arms (in mm)	
	700
H (max.) Loading height unloaded	1256
H (min.) Loading height loaded	906
F (max.) Middle of main beam to upper edge of loading floor	728
K (min.) At dimension F (max.)	515
D (min.) Installation space (min.)	665
F (min.)	529
K (max.) At dimension F (min.)	710
D (max.) Installation space (max.)	860

Technical data

C 1000 S	
Lifting capacity	1000 kg
Main beam	180 x 180 mm
Lifting gear hydraulics	2 x lift cylinder / 2 x tilt cylinder
Platform overlap with floor	-57 mm
Lift arm pitch	1310 mm
Load centre - lengthwise	700 mm
Load centre - across centre	50 % of the full load on one side
Inclination angle of the platform	+90° to -10°

Diagram

C 1000 S	
a (mm)	Q (kg)
700	1000

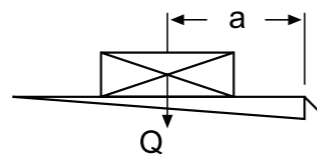

Disclaimer: The specified weights refer to the lightest platforms of the corresponding height. Dimensions may vary. Specifications subject to change without notice.

FEATURES: Fixed control • pendant control • platform auto levelling • roll stops • flashing lights • foot controls

MBB C 1500 S

PALFINGER

Heavy duty use, exceptional performance

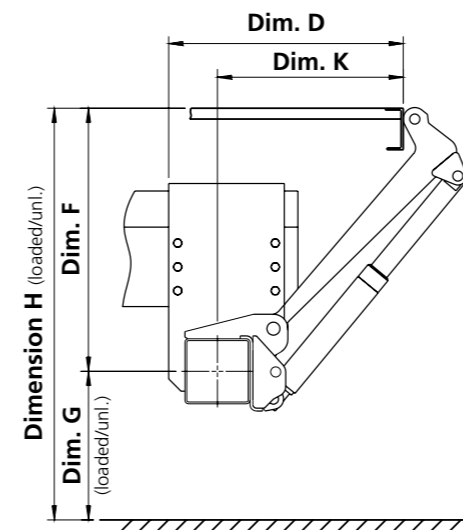

Weights

C 1500 S	
Platform type	Alum.
Platform width (mm)	2450
Platform height (mm)	2200
Unit weight (kg)	548
Adds to vehicle (mm)	235*

* Does not include seal kit or pressing

Dimensions

C 1500 S	
Lift arms (in mm)	
	700
H (max.) Loading height unloaded	1200
H (min.) Loading height loaded	883
F (max.) Middle of main beam to upper edge of loading floor	650
K (min.) At dimension F (max.)	618
D (min.) Installation space (min.)	768
F (min.)	508
K (max.) At dimension F (min.)	726
D (max.) Installation space (max.)	876

Technical data

C 1500 S	
Lifting capacity	1500 kg
Main beam	180 x 180 mm
Lifting gear hydraulics	2 x lift cylinder / 2 x tilt cylinder
Platform overlap with floor	-63 mm
Lift arm pitch	1300 mm
Load centre - lengthwise	1000 mm
Load centre - across centre	50 % of the full load on one side
Inclination angle of the platform	+90° to -10°

Diagram

C 1500 S	
a (mm)	Q (kg)
1000	1500

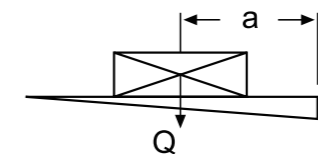

Disclaimer: The specified weights refer to the lightest platforms of the corresponding height. Dimensions may vary. Specifications subject to change without notice.

FEATURES: Fixed control • pendant control • platform auto levelling • roll stops • flashing lights • foot controls

PALFINGER AUSTRALIA

PHONE: 13 27 26

palfinger.com.au info@palfinger.com.au



PALFINGER AUSTRALIA

PHONE: 13 27 26

palfinger.com.au info@palfinger.com.au



MELBOURNE • SYDNEY • NEWCASTLE • BRISBANE • PERTH

MELBOURNE • SYDNEY • NEWCASTLE • BRISBANE • PERTH

MBB C 2000 S

PALFINGER

Ideal for heavier loads

PALFINGER

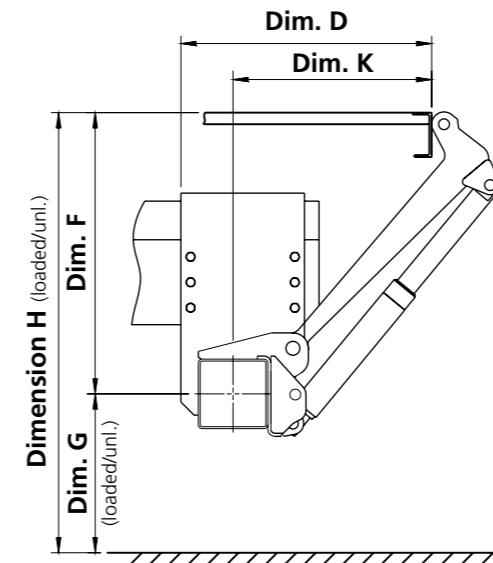

Weights C 2000 S

Platform type	Alum.
Platform width (mm)	2450
Platform height (mm)	
2000	535 kg
2200	552 kg
2400	569 kg
2600	585 kg
2800	601 kg
Adds to vehicle (mm)	235*

Platform type	Steel
Platform width (mm)	2450
Platform height (mm)	
2009	691 kg
2209	718 kg
2409	745 kg
2609	771 kg
Adds to vehicle (mm)	235*

* Does not include seal kit or pressing

Dimensions

		C 2000 S
Lift arms (in mm)		800
H (max.)	Loading height unloaded	1345
H (min.)	Loading height loaded	916
F (max.)	Middle of main beam to upper edge of loading floor	785
K (min.)	At dimension F (max.)	641
D (min.)	Installation space (min.)	791
F (min.)		566
K (max.)	At dimension F (min.)	820
D (max.)	Installation space (max.)	970

Technical data

		C 2000 S
Lifting capacity		2000 kg
Main beam		180 x 180 mm
Lifting gear hydraulics		2 x lift cylinder / 2 x tilt cylinder
Platform overlap with floor		- 63 mm
Lift arm pitch		1300 mm
Load centre - lengthwise		1000 mm
Load centre - across centre		50 % of the full load on one side
Inclination angle of the platform		+90° to -10°



Diagram

C 2000 S

a (mm)	Q (kg)
1000	2000
1250	1600
1600	1250
1900	1050
2200	910

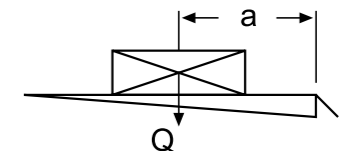

Lifting a full 2000 kg, the MBB C 2000 S is the tail lift of choice for the food and drink distribution industry. Its reliable and heavy duty four-cylinder lift mechanism is available with a wide variety of steel or aluminium platforms, up to a maximum height of 2600 mm.

FEATURES: Fixed control • pendant control • platform auto levelling
• roll stops • flashing lights • foot controls

Disclaimer: The specified weights refer to the lightest platforms of the corresponding height. Dimensions may vary. Specifications subject to change without notice.

PALFINGER AUSTRALIA

PHONE: 13 27 26

palfinger.com.au info@palfinger.com.au



PALFINGER AUSTRALIA

PHONE: 13 27 26

palfinger.com.au info@palfinger.com.au



MELBOURNE • SYDNEY • NEWCASTLE • BRISBANE • PERTH

MELBOURNE • SYDNEY • NEWCASTLE • BRISBANE • PERTH

MBB C 3000 S

PALFINGER

The most powerful lift in the range

PALFINGER



The MBB C 3000 S lift has been cleverly designed to provide exceptionally stable four-cylinder operation capable of lifting goods up to 3000 kg, making it ideal for the transportation of the heaviest loads. It is available with either a steel or aluminium platform with a load centre of 1000 mm. A powerful, low-noise powerpack in the square main beam reduces noise during loading or unloading to a minimum.

FEATURES: Fixed control • pendant control • platform auto levelling
• roll stops • flashing lights • foot controls

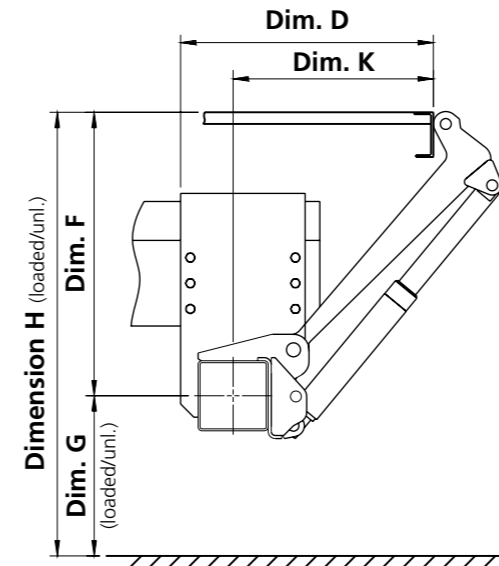

Weights c 3000 s

Platform type	Alum.
Platform width (mm)	2450
Platform height (mm)	
2200	737 kg
2400	780 kg
2600	823 kg
Adds to vehicle (mm)	275*

Platform type	Steel
Platform width (mm)	2450
Platform height (mm)	
2209	948 kg
2409	980 kg
2609	1001 kg
Adds to vehicle (mm)	275*

* Does not include seal kit or pressing



Dimensions

		C 3000 S
Lift arms (in mm)		900
H (max.)	Loading height unloaded	1554
H (min.)	Loading height loaded	1030
F (max.)	Middle of main beam to upper edge of loading floor	924
K (min.)	At dimension F (max.)	652
D (min.)	Installation space (min.)	807
F (min.)		645
K (max.)	At dimension F (min.)	901
D (max.)	Installation space (max.)	1056

Technical data

		C 3000 S
Lifting capacity		3000 kg
Main beam		190 x 190 mm
Lifting gear hydraulics		2 x lift cylinder / 2 x tilt cylinder
Platform overlap with floor		- 72 mm
Lift arm pitch		1300 mm
Load centre - lengthwise		1000 mm
Load centre - across centre		50 % of the full load on one side
Inclination angle of the platform		+90° to -10°

Diagram

C 3000 S

a (mm)	Q (kg)
1000	3000
1200	2500
1500	2000
1800	1650
2400	1250

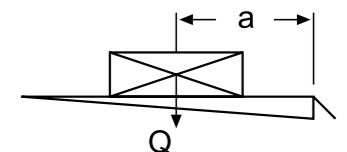

Disclaimer: The specified weights refer to the lightest platforms of the corresponding height. Dimensions may vary. Specifications subject to change without notice.

PALFINGER AUSTRALIA

PHONE: 13 27 26

palfinger.com.au info@palfinger.com.au



PALFINGER AUSTRALIA

PHONE: 13 27 26

palfinger.com.au info@palfinger.com.au



MELBOURNE • SYDNEY • NEWCASTLE • BRISBANE • PERTH

MELBOURNE • SYDNEY • NEWCASTLE • BRISBANE • PERTH

MBB R 2000 S

PALFINGER

Heavy duty for heavy loads

PALFINGER



The MBB R 2000 S is a robust and retractable lift with a 1000 mm load centre. A push-pull cylinder aligned lengthwise moves the lift into the desired position. Stowing completely out of the way under the rear of the vehicle it is ideal for fork lift and dock loading operations. The KTL-coated lifts leave the factory fully assembled and supplied with kits ready for installation to trucks or trailers. The 2000 kg model's single fold platform is all aluminium. When stowed, the lift forms the vehicle's under-run bumper. The lifts are entirely operated by a user friendly MBB control system.

- FEATURES:** Fixed control • pendant control • platform auto levelling
• roll stops • flashing lights • foot controls

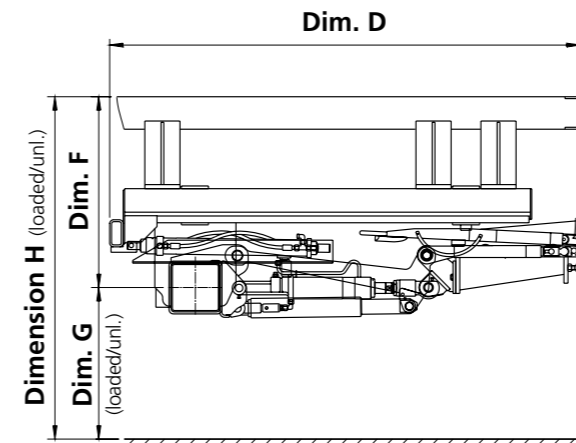

Weights

R 2000 S

Platf. type Alum./Alum.	
Platform width (mm)	2300
Platform height (mm)	1820
Unit weight (kg)	665
Weight of retraction unit	175 kg

Dimensions

		R 2000 S
Lift arms (in mm)		900
H (max.)	Loading height unloaded	1444
H (min.)	Loading height loaded	1006
F (max.)	Middle of main beam to upper edge of loading floor	820
K (min.)	At dimension F (max.)	751
D (min.)	Installation space (min.)	1900
F (min.)		614
K (max.)	At dimension F (min.)	907
G (max.)	Unloaded (middle of main beam to ground)	624
G (min.)	Loaded	392
E (max.)	Vehicle frame width (max.)	920
E (min.)	Vehicle frame width (min.)	645

Technical data

		R 2000 S
Lifting capacity		2000 kg
Main beam		180x180 mm
Lifting gear hydraulics	2 x lift cylinder / 2 x tilt cylinder / 1 x moving cylinder	
Lift arm pitch		1300 mm
Load centre - lengthwise		1000 mm
Load centre - across centre	50 % of the full load on one side	
Inclination angle of the platform		+10° to -10°



Diagram

R 2000 S

a (mm)	Q (kg)
1000	2000
1200	1650
1500	1350
1800	1100

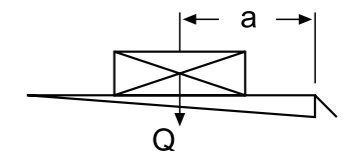

Disclaimer: The specified weights refer to the lightest platforms of the corresponding height. Dimensions may vary. Specifications subject to change without notice.

PALFINGER AUSTRALIA

PHONE: 13 27 26

palfinger.com.au info@palfinger.com.au



PALFINGER AUSTRALIA

PHONE: 13 27 26

palfinger.com.au info@palfinger.com.au



MELBOURNE • SYDNEY • NEWCASTLE • BRISBANE • PERTH

MELBOURNE • SYDNEY • NEWCASTLE • BRISBANE • PERTH

FTK600E

Light weight, easy to fit



The FTK600E is a compact tail lift with a foldable platform and a loading capacity of up to 600kg. This results in an optimal weight-to-capacity ratio. The low weight is achieved with an aluminium platform and innovative design. The folding platform stows under the vehicle chassis and is simple to operate and quick to install. Comes standard with mechanical auto-levelling for increased stability when lifting larger loads.



Designed and manufactured for Australian conditions.

FEATURES: Fixed control, pendant control, platform auto levelling

FTK600E

Specification	FTK600E
Lift Capacity	600kg
Nominal Platform Size	1530mm W x 950mm L
Platform Finish & Construction	Anodised 2 piece single fold extruded aluminum alloy
Load Centre	500mm
Nominal Unit Weight Installed	150kg (Extension plate built into truck floor). 180kg (Extension plate added to vehicle)
Nominal Centre Of Gravity Of Unit When Stowed	340mm
Nominal Fitting Requirements	1100mm maximum floor height unloaded 800mm minimum floor height loaded *800mm min. underbody clearance for 800mm floor height *720mm min. underbody clearance for 1100mm floor height
Adds To Vehicle Length	N/A (0mm) for extension plate built in as part of body length 205mm for extension plate added to body length
Battery Isolation Switch	Yes
Controls	Removable IP65 rated two (2) button hand control c/w 2.75m lead plus fixed controls in lockable weather-proof metal box
Lifting Operation	Power up / gravity down – automatic levelling at ground
Speed Down	Adjustable flow control factory pre-set to maximum 100mm/sec complete with velocity fuse
Closing / Opening Operation	Manual (torsion spring assisted opening and closing)
Platform Stowed Lock	Manual cable & hasp
Low Maintenance Bushes	Yes
Pins	Zinc plated Ø25 mm dia. high grade bar
Hydraulic Power Pack	Heavy duty 0.8kw in weather-proof noise dampening enclosure

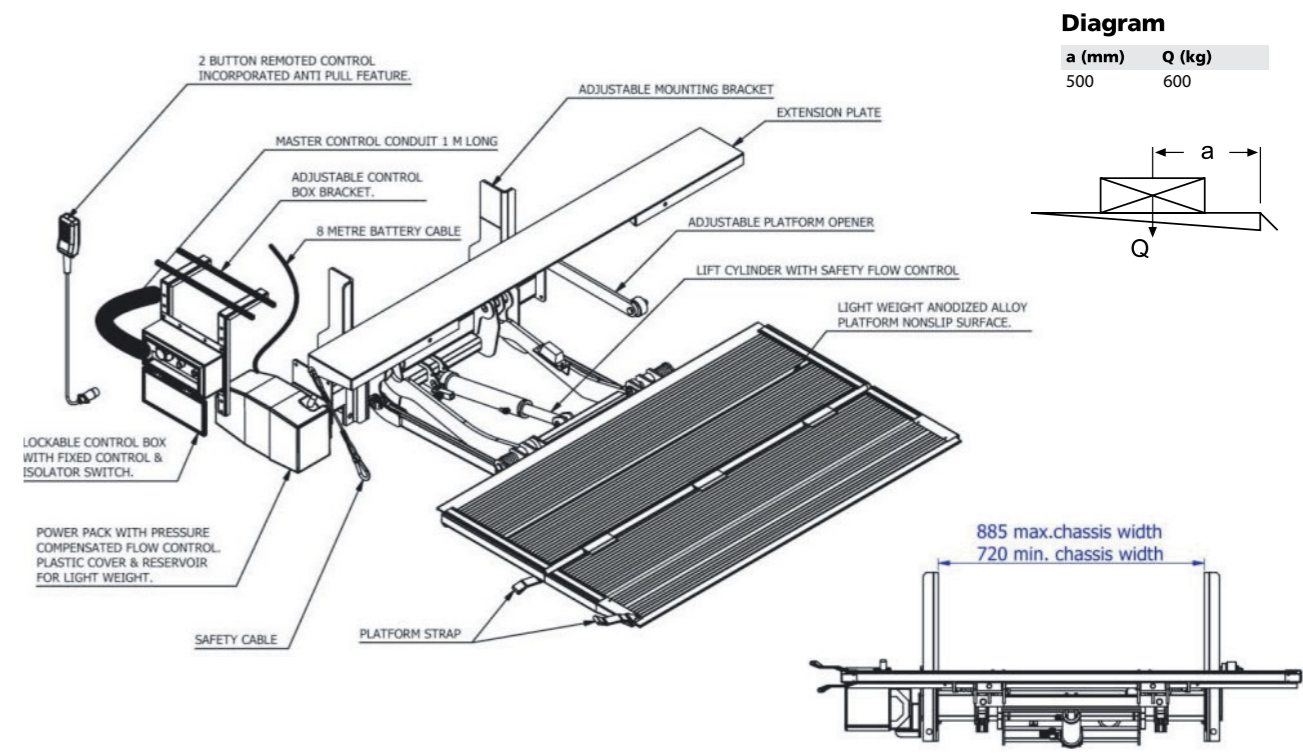

Disclaimer: The specified weights refer to the lightest platforms of the corresponding height. Dimensions may vary. Specifications subject to change without notice.

PALFINGER AUSTRALIA

PHONE: 13 27 26

palfinger.com.au info@palfinger.com.au



PALFINGER AUSTRALIA

PHONE: 13 27 26

palfinger.com.au info@palfinger.com.au



MELBOURNE • SYDNEY • NEWCASTLE • BRISBANE • PERTH

MELBOURNE • SYDNEY • NEWCASTLE • BRISBANE • PERTH

OPTIONS



Safety gates

Palfinger Australia offer safety gates for the PALFINGER tail lift range. Fully adjustable mount positioning of the vertical gate supports provides a one size fits all application. Horizontal rails come in 2.5mt lengths and can be cut to suit the platform length desired. Gas shocks offer ease of open/close function and a locking mechanism comes with pull strap so operators don't have to bent down to unlock the safety gates before placing in stowed position.



Wireless control

The new MBB remote control BT (= Bluetooth®) has been developed for maximized user-friendliness and optimized for ease of use. An ergonomic design, the easy to grip surface and the low weight all contributes to the new hand held unit. The remote control works with the latest Bluetooth® 5.0 technology. This guarantees a fast and secure operation of the tail lift and additional connected devices without any loss of performance e.g. through frequency disruptions. The data transmission is bi-directional. If the connection is interrupted the tail lift will stop automatically.



SERVICE & SUPPORT



Warranty information

Palfinger Australia reflects the warranty conditions of the manufacturer. Unless otherwise stated this warranty policy warrants products sold by the company against defective material and workmanship for a period of 24 months service.

The manufacturer's warranty excludes normal wear and tear, damage from misuse, improper installation or maintenance, labour, loss of time or usage, or subsequent damage

The Palfinger brand essence

LIFETIME EXCELLENCE is our promise, our central message, the core of our brand. For our customers, it means uncompromising top performance. The most economical, reliable and innovative lifting solutions in a global network of professional service partners – for the lifetime of the product.

Professionals need product solutions with excellent lifecycle performance. High resale value, shorter downtime and durable components result in outstanding cost balance – decisive reasons for our customers to invest in PALFINGER products. They know that, along with excellent performance, they are getting the most cost-effective and economical product solutions in the long term.

The Palfinger brand values

Economy

PALFINGER products offer an outstanding price-performance ratio. High productivity, ease of use, a close-knit service network as well as high resale value more than pay for the investment in a PALFINGER product over the period of its use.

Reliability

Premium quality and strength of the products, durable components and outstanding workmanship, dependable worldwide service as well as the company's stability and strength make PALFINGER a reliable partner for professionals.

Innovation

PALFINGER is committed to leadership in innovation. In the past, trailblazing developments have revolutionised products and, in future, intelligent system solutions and unique functionality from PALFINGER will also shape the industry and new product development.

LIFETIME EXCELLENCE		
EFFICIENCY		
RELIABILITY		
INNOVATION		
TOP PERFORMANCE	TOP PERFORMANCE	SERVICE CHAMPION
ONLY THE BEST	PARTNER FOR PROFESSIONALS	GLOBAL LOCAL PLAYER
LEADING INNOVATIONS	INTELLIGENT SYSTEMS	TOUCH AND FEEL

Service Partners

Palfinger Australia – a division of Sime Darby Motors – is a major supplier for the truck, trailer, hook loader and skip bin markets in Australia. Palfinger Australia has built its reputation on tier 1 quality product and service excellence; providing support at the point of specification, expert technical advice and first-class aftermarket support. This is helping to shape Palfinger Australia as the leading partner for businesses large and small within the transportation sector in Australia.

Palfinger Australia has 35+ partners across Australia to service your tail lift and hydraulic needs. From specification through to application, Palfinger Australia will be with you every step of the way. Palfinger Australia offers a dedicated warranty system to identify and rectify issues in the workshop, or on the road for any given situation. Using the latest technology, Palfinger Australia is able to react quickly and flexibly to customer requirements.

The diversity of Palfinger Australia is such that it offers design, supply, manufacture, installation and service for all product supplied – a unique characteristic when compared to competitors. Palfinger Australia has an underlying commitment to quality and innovation and understands that “total cost of ownership” to owner drivers and fleets is paramount in minimising downtime and creating value through full service lifecycle of the product.



BROADER APPLICATIONS



PALFINGER AUSTRALIA

PHONE: 13 27 26

palfinger.com.au info@palfinger.com.au



PALFINGER AUSTRALIA

PHONE: 13 27 26

palfinger.com.au info@palfinger.com.au





PALFINGER

LIFETIME EXCELLENCE

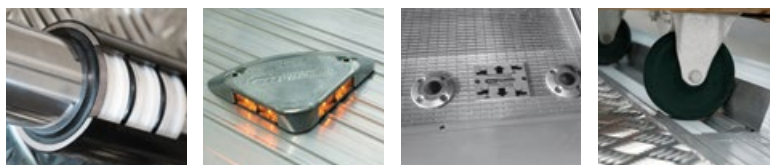

PALFINGER AUSTRALIA

PHONE: 13 27 26

palfinger.com.au

info@palfinger.com.au

A  **Motors Company**

MELBOURNE • SYDNEY • NEWCASTLE • BRISBANE • PERTH